

带座外球面球轴承

UCP2立式带座外球面向心球轴承组件带止动螺钉

钉-UCP205-013D1+UC205-013D1+P205D1Z(ZM)-UCP205-013D1C(CM)-UCP205-013D1

参数信息:

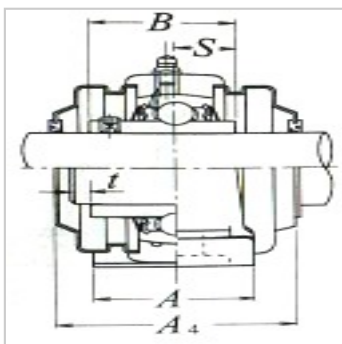
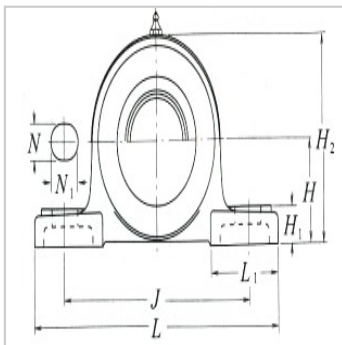
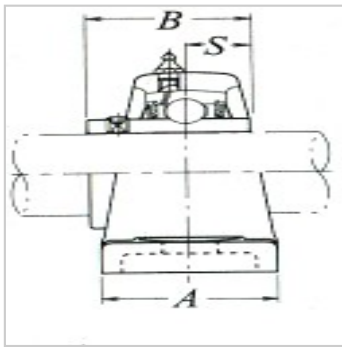
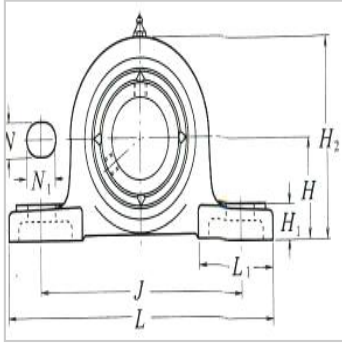

轴径inch :	13/16
座组件轴承型号(1) :	UCP205-013 D1

尺寸inch :	
H :	17/16
L :	5 1/2
J :	4 1/8
A :	1 1/2
N :	1/2
N :	5/8
H :	19/32
H :	2 25/32
L :	1 21/32
B :	1.3425
S :	0.563

安装螺栓规格inch :	3/8
--------------	-----

轴承代号 :	UC205-01 3D1
--------	-----------------

座外型号 :	P205D1
--------	--------

带钢板外罩座组件轴 承型号 :	Z(ZM)-U CP205-01 3D1
--------------------	----------------------------

带铸铁外罩座组件轴 承型号 :	C(CM)-U CP205-01 3D1
--------------------	----------------------------

尺寸inch :	
t(最大) :	5/64
A :	1 29/32
H :	3
A :	2 3/4

带座轴承重量lb :

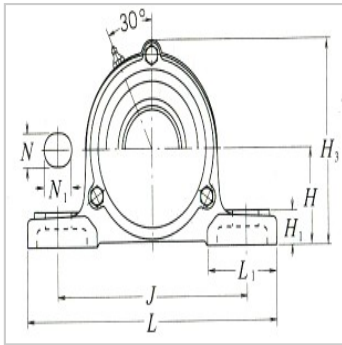

UCP :	1.8
Z(ZM) :	2.0
C(CM) :	2.6

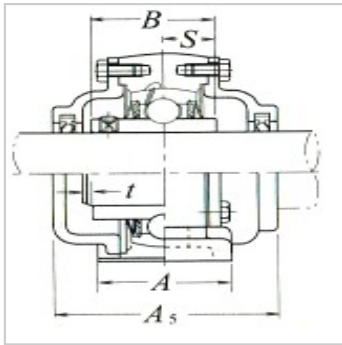

: